

The ARPAM Project

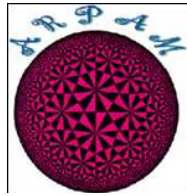

Claude Paul Bruter

1. Introduction

It has been twenty years since I initiated the idea to create an architectural complex dedicated to the popularization of mathematics. Several small buildings, called follies, containing artistic and pedagogical objects were to be placed among the trees in a large wooded area.

At that time, the French Minister of Research had asked me for a Feasibility Study. I would like to cite the preamble of the Study, entitled:

"Why Create a Park for Promenade and Mathematical Activities?"

"The true elevation of a society's intellectual level, in itself a noble and useful objective, is accompanied by the elevation of its cultural level, a factor essential to producing an open mind.

Authentic culture is universal in character. It is not only literary or artistic; it is also scientific. Since mathematics takes an important place among the sciences, everyone should be allowed access to this form of culture.

The goal of all disciplines should be the fashioning of the mind. To this end, mathematics is irreplaceable. The teaching of mathematics stimulates the explicative faculties

and the ability to make syntheses. It excites the imagination, develops the capacities of mental observation, and exercises reflection.

The value of mathematics is not only pedagogical, however. It is also a formidable tool toward understanding worldwide, a tool used in fundamental as well as applied sciences.

For cultural and educational reasons, it is important that all be able to benefit from the tremendous enrichment that knowledge of mathematics can bring.

Unfortunately, however, there can occur obstacles to the accessibility to mathematical understanding, due to psychological, emotional, intellectual or educational problems. These can result in a lack of basic training as well as a lack of qualified teachers.

These are the reasons which have led us to campaign for the establishment of a Park of Promenade and Mathematical Activities.

The primary goal of the Park should be to eliminate the psychological barriers which discourage some students from undertaking mathematical studies. We intend to reach our goal by emphasizing the aesthetic qualities inherent in each of the mathematical objects.

The mere sight of these objects can evoke admiration, surprise and curiosity. They can lead the visitor to try to understand what is being represented, to further explore some of the themes.

Of course, no knowledge is required to view the Arch of Triumph, the Concord Obelisk or the Champs Elysees, or to enjoy the architectural beauty of the city, its parks, forms, colours, and lights.

While admiring the original and beautiful works displayed in the Park, diverse publics of all ages could, at the same time, come into contact with certain basic elements of classical and contemporary mathematics, thereby entering this enriching universe.

A Mecca for tourists, to this day unique in its conception, this Park of contemplation and meditation could also serve as a Park of initiation, contributing to personal fulfilment."

I would like to add here a few comments which will shed more light on the content of the Park.

In the public mind, and often in the mathematical experience, mathematics is viewed as an abstract science. These are hasty and partially inexact presumptions. Mathematics makes use of a particular language. It represents forms and the processes of evolution and creation. Mathematics is an

abstract form of physics, a step-by-step construction, the first stage directly related to the physical world, and each successive stage being built on those preceding by the same process of observation and by retaining properties, in their fundamental and general form, and where physical causality, closely related to a presence of stability, is expressed in the form of a causality of logic, implying an affirmation toward another possibility.

If only by its origins, then, mathematics is directly connected to reality, and to the physical world in particular. Through their sensorial system, particularly that of sight, people, especially children, are very receptive to the material world surrounding them. This fact alone has an immediate pedagogical consequence. That is that access to the world of mathematical representations would become much easier if these objects could somehow take material form. And why not endeavour to do this as aesthetically as possible ? Works of art, paintings, sculptures, and architectural works deserve to be exhibited and appreciated, even the more so as part of their technical production and foundation is based on mathematical principles.

Bourbaki named certain local elements "structures". It is, of course, much more difficult to present the architecture hidden in the completed mathematical edifice through structures which are intertwined, through the criss-crossing of theories and the new objects which result from them.

All constructions are created over a period of time, and are supported by a foundation. It is therefore the historic view of the development of mathematics which should bring out the architecture of mathematics. One not fixed in time, like that of a building, but one which on the contrary, could present an internal dynamic, analogous to that of a living being.

It is in the above-mentioned spirit that the ARPAM project has been conceived. It is now carried by the Association ARPAM and by ESMA, the European Society for Mathematics and the Arts.

2. The Arpam Project

The historic fundamentals of mathematics are the numbers and the geometrical forms, these being the measurable and measured forms behind which the number is concealed or revealed. I have chosen to honour the number in two ways. The first concerns quantity, that of the follies in the Park. We know how important the *tetractys* and the number 10 was to the Pythagoreans (and to the Egyptians, whence it might come). I have therefore decided on 10 for the number of follies.

We also know how important to the Egyptians were the "Houses of Living", whose purpose was to train scribes and priests. In memory of these important centres of learning, I have named the folly dedicated to the number, "The Number House" or "The Fermat Hotel".

An expose describing a folly in all of its architectural and decorative detail can take one hour. Please note that these are small buildings built on a human scale, not higher than 15 meters.

Now I hope you will excuse me for giving you a brief explanation. The following drawing will give you a general idea of "The House of Numbers".

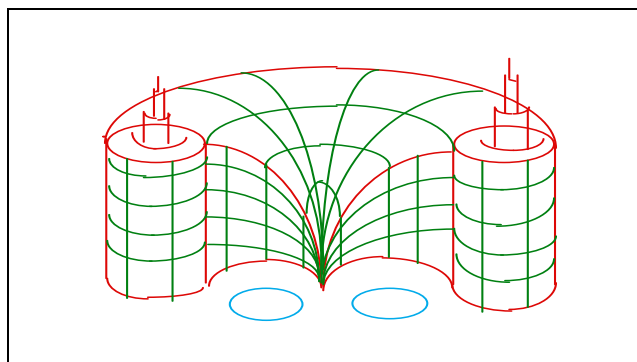

The House of Numbers

Classical curves were used in its conception: circles, parabola, ellipses and strophoids for the equation containing angle cosines and logarithmic curves.

There are circular towers topped by helicoids. These architectural elements represent what Gauss called "complex numbers", which I prefer to call Chuquet numbers, for Chuquet was the first to formally introduce them in 1484.

The classical real numbers, such as pi and e are inscribed in architecture. For example, the equations of the ellipses have the coefficients a_i and b_i where the ratio $a_i/b_i = 19/14$ is close to $e/2$. The decimal development of several of these numbers also appears on the rear wall of the building. This is in memory of my student days, when I spotted, written on the wall of an oral examination room, a long series of numbers, followed by a quotation ascribed to Shakespeare: "It is better to be brief than boring."

The building's exterior is very bright, covered by sheets of metallic glass for instance, while the interior is dark. This is to demonstrate that the properties of numbers remain enveloping many mysteries.

The entry and exit will take place through towers lit up at the base by strong beams of light.

Except for these openings and a luminescent section situated in the middle of the rear wall, the inside will be relatively dark, although light enough to be permit the lecture of lines of numbers formed thus:

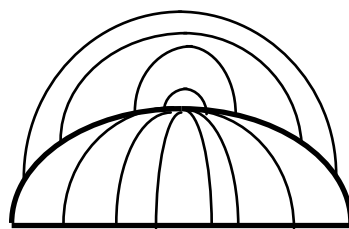

I mentioned the mysteries hidden in the theory of numbers. They are related in the manner by which numbers in general are constructed from prime numbers, the latter being known since antiquity. These gave rise to two conjectures, apparently more difficult to prove than those of Fermat and Poincare, which have been solved. These are the conjectures of Goldbach and of

Riemann. They will be represented in the House of Numbers via decorations and paintings, such as those created by Jean-Francois Colonna, partially using a cut-off of the Euler-Riemann zeta function.



**Jean- François Colonna
Monument Valley at sunset, 1997**

The second folly is related to geometry in its most ancient constituents perhaps, because they concern the construction of temples and their decoration, using tilings. Tiling has proved itself to be a remarkably universal decorative element, travelling easily through time and space.

This folly is named "The Seventh Temple", as it should be.

It does indeed have seven interior faces named Galois, Cayley, Hamilton, Jordan, Lie, Chevalley and Coxeter, respectively. These seven faces refer to the seven families of possible friezes. The folly has seventeen exterior faces which remind us that seventeen is the number of non-isomorphic types of tiling in the Euclidean plane.

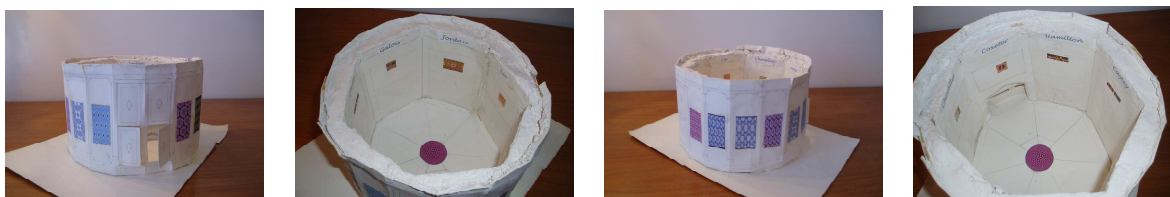

The hyperbolic ground tiling, the Klein tiling (2, 3, 7), is found on the dome of stained glass, which the rays of the midday sun project onto the tiling plane. In this folly the past joins the present via the theory of groups.

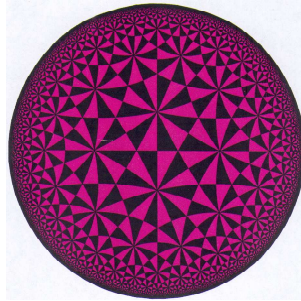

(2, 3, 7) Kleinian tessellation

There are many motifs and productions of tilings. Mike field and Jos Leys have created a great many patterns of the Euclidean and hyperbolic planes, respectively. Temporary exhibits could be displayed on the inner and outer walls of the seventh Temple, such as this one by Mike Field:



I will mention in passing the five other follies:

The Apollonius Headdress, which celebrates the study of conics, whose role was so important in representing and understanding the movement of the planets, and of cinematic and dynamic physics.

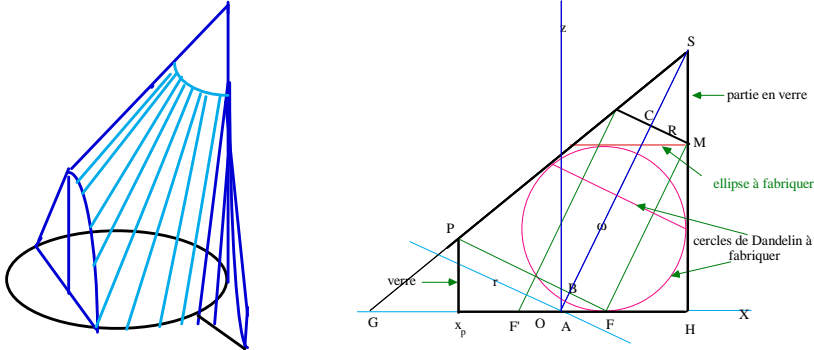

- *The Horn of Plenty*, marking the introduction of European mathematics, with the idea of recurrence, appearing in the work of Fibonacci and continuing into the 17th century with number sequences and series. These led to analysis and to the modern illustration of the world of fractals.

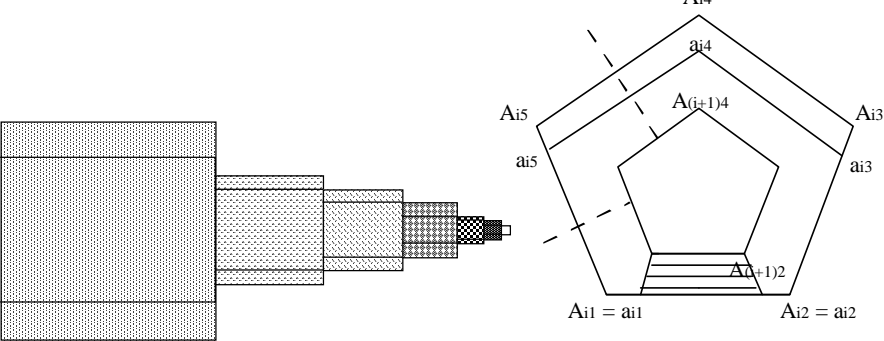

Fractals by Geraud Bousquet and Jeremie Brunet

- *The Euler Bridges*, marking the introduction of graph theory (1759), linked to early topological considerations. From an architectural point of view, this is not a representation of a building, but a small-scale reconstitution of the Koenigsberg (Kaliningrad) bridges. These would span a small, flower-lined pond, permitting the visitor to reflect and take a well-earned rest, having explored much of the Park.

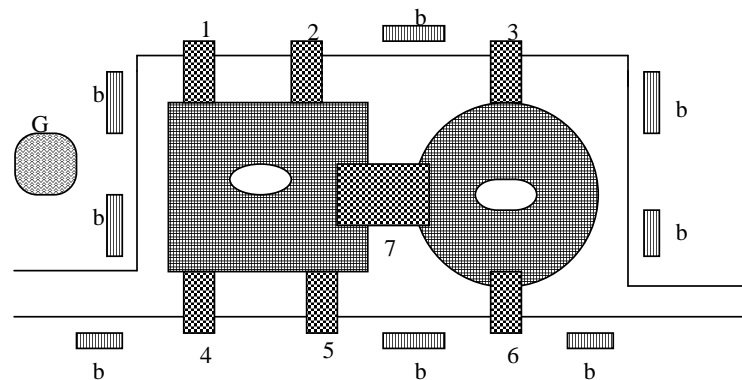

- *The Gauss Observatory*, evoking the early development of differential geometry.

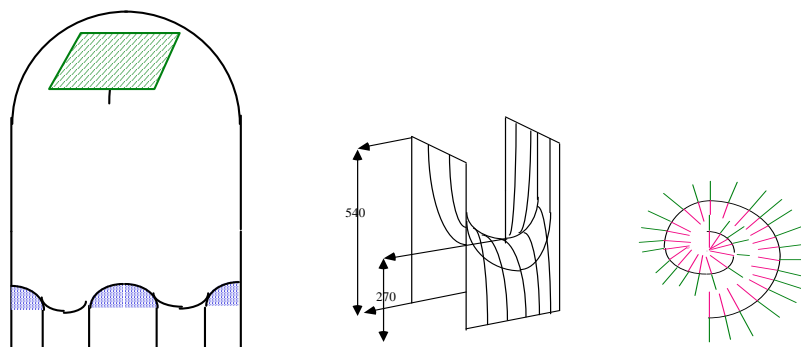

- *The Luminous Torus* is not, like the preceding follies, related to the development of mathematics in the past. It concerns recent aspects of differential topology through the relations between tori and spheres on one hand, and of differential analysis on the other hand, with its applications to the study of light phenomena.

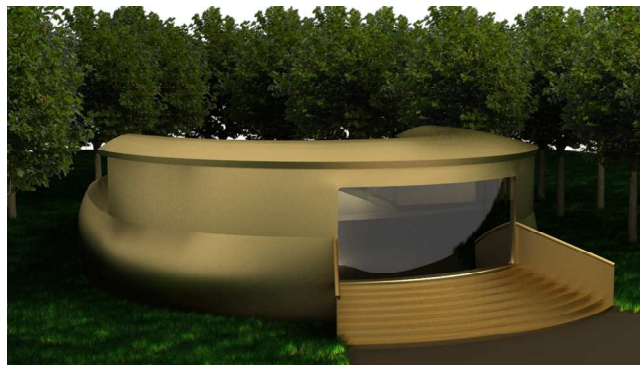
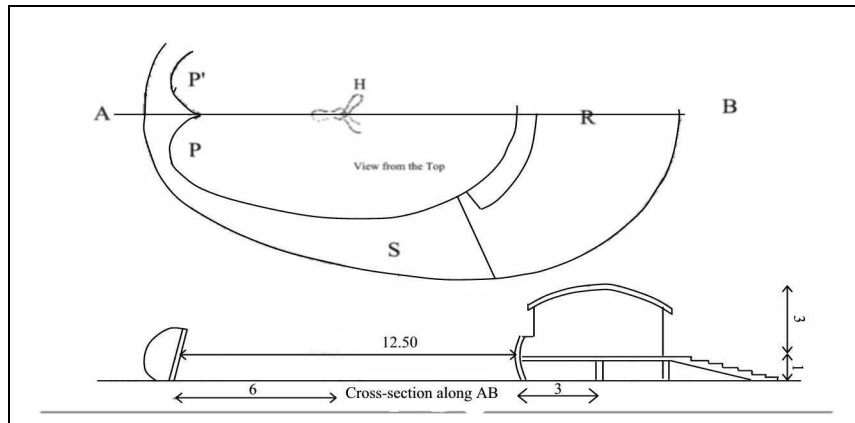

A first sketch of the folly

Is it necessary to recall the importance of these phenomena, of their underlying physics which has been particularly stable since the big-bang ? They have generated geometric optics as well as proper Euclidean geometry by means of the famous Thales theorem, the latter being the result and the codification of elementary observations of shadows of obelisks brightly illuminated by the sun.

I will speak more about the last three follies, two of which illustrate several important concepts.

1) *Whitney's Umbrella*: We can observe this object at the crossing of different branches of mathematics, i.e. algebraic and analytical geometry, and differential analysis and differential topology.

Among the most important mathematical and physical concepts, four are associated with this "umbrella". These are: singularity, stability, bifurcation and stratification.

The *singular object* is the particular object with extremal properties, degenerate as regards a form of specialization, totipotent, surrounded by a local universe whose properties are dependent on the singular object.

The *stable object* is that which lasts, and because it is water and shock-resistant, is most utilized in construction. It conserves its basic, intrinsic properties even under conditions which might deform it.

Disturbances can be caused by outside influences, called parameters. An object can remain stable as long as its parameters move within a precise domain. As soon as the parameters cross over the boundary of that domain, called the *bifurcation set*, the object can undergo greater or lesser changes. The bifurcation set defines the object' domains of stability.

The geometrical objects are organized into sub-objects called *strata*, which are connected to each other.

These concepts are of special interest because of their precise description and understanding of phenomena in the fundamental sciences as well as in everyday life.

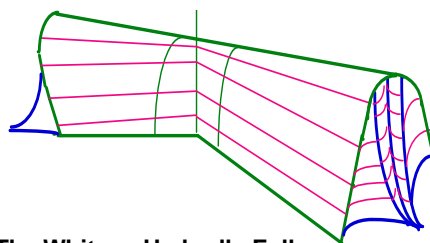

The Whitney Umbrella Folly



Mathematical Image by Tom Banchoff

The umbrella constitutes in itself a ruled surface, easy to construct, with a glass centre. The front parts of the structure, containing the points of entry and

exit of each room, are sections of homeomorphic objects to the umbrella called "swallows tails". They will be slightly engulfed by the umbrella.

2) *The Poincaré Surprises*: The follies I have presented until now are mainly linked with the static aspects of mathematics. Static states can be understood as the final stable stages of evolutions. These evolutions can be very fast or very slow according to the temporal scale of observation. The fact is that they underlie the birth, morphology, and activities of all objects in Nature. Any attempt at popularising mathematics must include to exhibit the analysis of the incarnation of movement into the physical world made by mathematicians. This analysis has given rise to the extremely important cinematic and dynamical theories that are present within the physical and the mathematical worlds.

The history of these theories begins more or less with Galileo and Newton. From that time until Poincaré, efficient mathematical tools were developed to master the analysis of motion: series, differential and partial differential equations. While these tools do have a geometrical substratum, it is usually hidden in contemporary teaching. Thus, these tools seem to be based only on numerical laws and algorithms.

Until Poincaré, during the second half of the nineteenth century, there was no general geometrical theory directed to the study of motion which was able to show and to classify the various behaviours of the trajectories characterizing the different families of motions. Poincaré introduced such a theory and began to study it, at first when the motion was on 2-dimensional surfaces.

Again, the two important concepts, those of singularity and bifurcation, linked through the fundamental concept of stability¹, arise in that study.

¹ The concept of stability could be the most important universal concept in natural science. An intelligence as keen as Plato's did not ignore it. It appears in his natural philosophy when Diotime says in the Banquet that "the mortal nature always tries, as much as it can, to reach perpetuity and immortality", an aim that has been generalized by Spinoza who said that "any thing ... always remains steadfast in one's state". This metaphysical notion takes many faces and indeed underlies all mathematical activities.

The purpose of the folly *The Poincaré Surprises* is to visualize some of the main concepts mainly through the exhibition of suitable families of physical trajectories.

The use of properties of some fluid flows on certain surfaces is the main tool which is used to exhibit these concepts and mathematical facts. The artistic attraction of this folly comes from the multiple effects of light through the various uses of the fluid elements.

The main building has a rotating axis of symmetry, which is inside an optimal designed column. On the ground, inside the building, in principle, it moves a cylinder which is the inner vertical border of a basin having the shape of a ring. This basin will be named the *Poincaré-Birkhoff ring*.

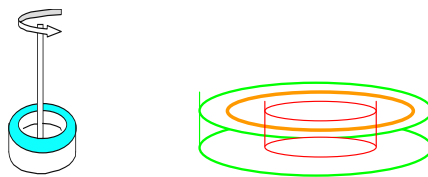

The Poincaré-Birkhoff ring

Its outer vertical border should be turning in the opposite sense of the inner cylinder : then, by friction and capillarity, the water in the basin, close to the borders of the cylinder, is moved in opposite directions. From time to time, a fluorescent jet of water comes out tangentially to each cylinder ; for instance, the one coming out from the inner cylinder is red, while the one coming out from the outer cylinder is green. In fact, here, the basin will be fixed, and the water will be put in movement by the actions of the jets. According to the speeds of the borders, or equivalently to the power of the jets, different behaviours of strings of water will be observed around the circle located in the middle of the ring.

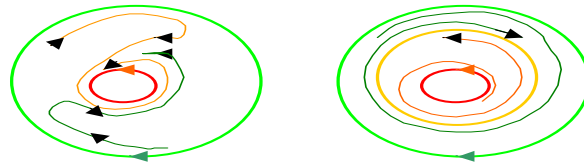

In particular, we get a physical illustration of a theorem first proved by G. Birkhoff that there exists an invariant trajectory in the middle of the basin. Hereafter are theoretical illustrations of two possible observations: the spectator will attend to the birth of invariant flow, here coloured orange, in the middle of the basin.

The roof has two parts: a fixed part and a moving part just above the fixed part. The rotating axis makes moving the upper part of the roof which is like a wheel. It is transparent, so that one can observe fluids which are flowing between the two parts. These fluids, which can be coloured, are pumped and are coming up inside the axis which also acts as a pipe. They are sent under pressure between the moving and the fixed roofs.

Through a system of small balls, the moving roof rolls upon the fixed roof. The speed of rotation can be changed.

Being located above the building, we can thus observe the surprising coloured trajectories on the roofs of the building. Many bifurcations processes will appear. They will vary with the pressure of the fluids, the speed of rotation of the upper roof, the exterior temperature and the climatic conditions. Falling down, the water makes a kind of crystalline bright curtain around the building.

This water falls down in some basins surrounding the main body of the building. One may imagine these basins as the little chapels forming the buttresses of a cathedral.

The sources are located at the highest places of this construction. Coloured water can spring from them. From time to time jets of water like

geysers are springing up. Saddle-points mark the limits of the influence of these sources. Sinks collect the water.

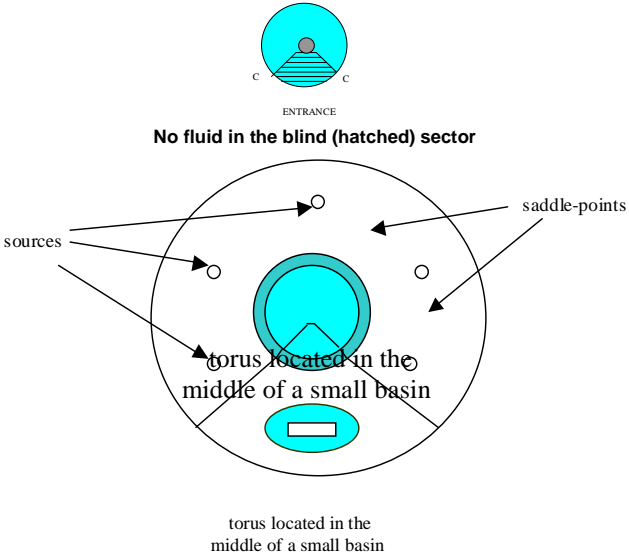

A 2-torus is placed before the entrance, in a small basin. There is a source at its top. We expect that the properties of capillarity will allow the liquid to cover all the surface in order to exhibit the usual singularities of the flow on the torus which are pointed out on the following drawing.

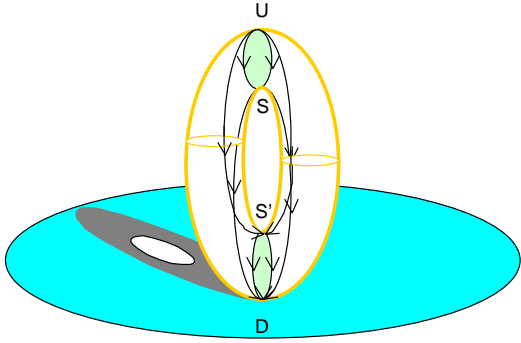

The stable flow on the 2-torus (U is source, D is a sink, while S and S' are saddle-points)

Decoration will show fixed or animated sequences of computed trajectories and phase-portraits. They can give rise to beautiful pictures.

The outline of the main body of the folly is a part of the hyperboloid of one sheet. This ruled surface is commonly used in architecture to make a water-tower. Its outside will be tiled with imitations of very large quartz crystals: they will reflect and diffract the light coming from projectors located around the main body of the folly. These projectors will also illuminate the bright curtain of fluids falling down from the roof.

Finally, above the central fixed part of the roof, a sculpture will symbolize the miracle of stability through an unfolding of a singularity. This sculpture will be a kind of flower with three leaves. Each leaf is viewed as a deformation of a half part of the Whitney umbrella.

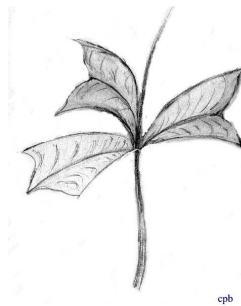

3) *The Boy Surface* or *The Boy Brioche*: This mathematical object gives rise to a quite new building whose architecture has never been conceived until now.

I chose this surface to illustrate topology, not only because of its novelty and its aesthetics, but also because it is an interesting topological object arising from projective geometry, and which was first used to set up a process for turning outside in the usual sphere.

From the mathematical point of view, the Boy surface is a representation of the whole set of lines passing by a common point in the usual 3-space. Each of these lines touches an hemisphere at one point if the line does not lay in the equatorial plane. In that case, it touches the equator in two points that have thus to be identified.

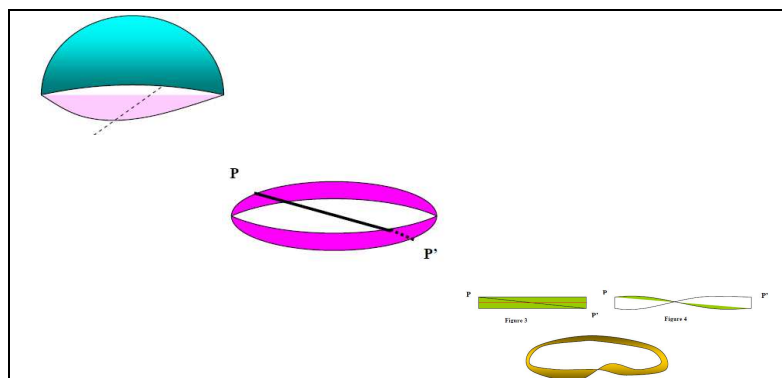

Then to get the Boy surface, we can first cut a small band containing the equator and identify the two opposite points on the equator: that operation is the same as building a Möbius band. The hemisphere without this band is like a 2-disk. We now get the Boy surface by identifying or sticking together the points of the boundary of the disk with the points of the boundary of the Möbius band. Since it contains a Möbius band, the Boy surface is non orientable like the Klein bottle.

The Boy surface was introduced by Boy at the beginning of the last century as an answer of a question by Hilbert. The algebraic equation of a geometrical realisation of the Boy surface was given by François Apéry in 1986.



Two physical representations of the Boy surface by François Apéry

Before showing you an outline of the building produced by Christophe Delsart and François Apéry, I would like to add a last word about the disposition of the follies in the Park.

The idea is that after leaving one folly, you walk along a path going up and down, rapidly surrounded by woods, so that you begin not to completely forget what you have just seen, but leaving the mind rest, it has time to assimilate the main feature and content of your recent visit. And then, hidden by the woods, you suddenly arrive on the next folly, being surprised by the new architecture and decoration you find. That shock helps to put in mind the main features of what you just have discovered.

Now here is a view of the Boy Surface from its outside.

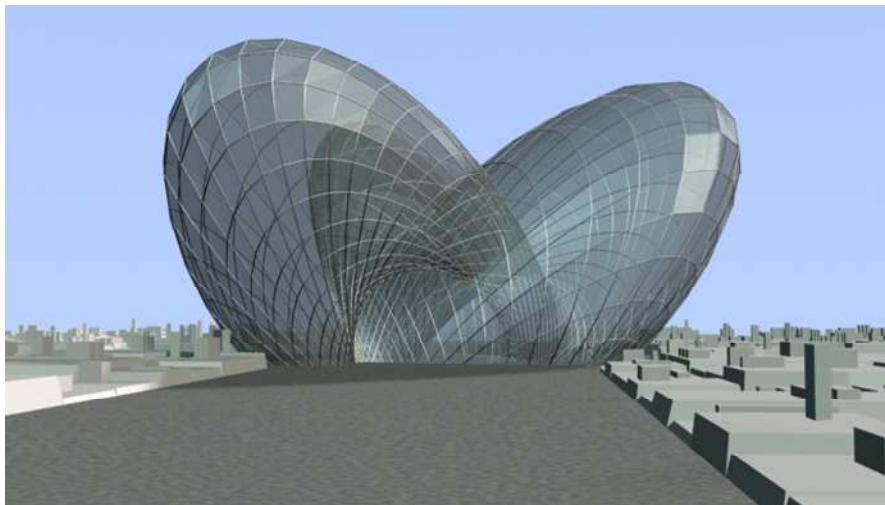

**Preliminary images of the stained glass folly
Christophe Delsart and Yvan Ngnodjom, 2008**

The Boy surface can be foliated with ellipses. Some well-chosen of them, materialized in chrome steel, constitute the main part of the frame of the folly.

This one has two parts: one which is visible from the outside, and the other one which can only be visible from the inside of the folly. Its floor lies on a perpendicular plane to the axis, located at approximately one third of the

height of the construction. This floor is transparent so that one can see the lower part of the construction from inside the folly. This lower part lies inside a cylinder plastered with broken mirrors which reflect the internal lights illuminating the frame.

A few Möbius bands are materialized with stained glass. By looking up and down, one can see them completely from inside the folly. The outside part of the folly has three pieces, but only two of them will serve as rooms for visitors. A series of vertical arches in the same material as the frame will cover the entrance of the two symmetric rooms.

Convenient transversal rods to the elliptic frame will define panels and allow us to cover the outside part with glass and mirrors. The elliptic curve will be replaced by a piecewise linear approximation. Then some of these panels will be partly stained glass windows showing either tilings or knots and braids with symmetries. LED's inserted in some panels will follow curves from knots: their representation in space will be improved using the fact that the angle between two consecutive panels of glass is not flat.

Beams of search-lights with convenient colours will illuminate the folly, and four sculptures placed around the folly as well.

To conclude, and with my warmest thanks for your attention, I shall show the very short movie made by Christophe Delsart and Yvan Ngnodjom from which you can have a glimpse to the interior of the folly (<http://christophe.delsart.free.fr/ARPAM/>).

Let us hope also that, been convinced by the mathematical and aesthetical interest of the project, an ancient Greek island might become a new tourist Mediterranean centre. Then, in that place protected by gods, will become incarnate the announcement by Anaxagoras of Clazomenae: « What is shown is a vision of the invisible ».

Acknowledgements: I would like to thank my ESMA translator, Sharon Breit-Giraud, for her kind help for the preparation of the text, the Hellenic Mathematical Society (Professors Grigoris Kalogeropoulos and Dimosthenis Varopoulos) and the Evgenidi Foundation for their invitation to present the Arpam project.